

VVS 4-1 Presorter

VVS stacks bundles of variable heights to bundles of almost equal height and enables automatic palletizing of ZIP-code productions.



Technical Specifications

Drive	Conveyor belt, frequency controlled
Control	PLC-control with direct connection to palletizer PC
Width	1524 mm
Length	1013,5 mm incl. control cabinet
Height	2230 mm
Inlet height	870 mm
Exit height	870 mm
Weight	approx. 750 kg
Product length	170 – 420 mm
Product width	148 – 280 mm
Bundle height inlet side	15 – 185 mm
Bundle height exit side	15 – 280 mm
Allowed overhang of foil or bottom sheet	max. 30 mm
Speed	max. 50 bundles/min. for strapped/foiled bundles
Conveyor belt speed	30 – 42 m/min.
Power	max. 4,1 kW
Voltage	230/400 V / N / PE, 3 Phase, 50 Hz
Fuse	3 x 25 A slow-blow fuse
Air consumption	max. 0,18 Nm ³ /min. unooled dry air
Air pressure	6 bar
Noise	< 70 dB (A) according to DIN 45635 part 1

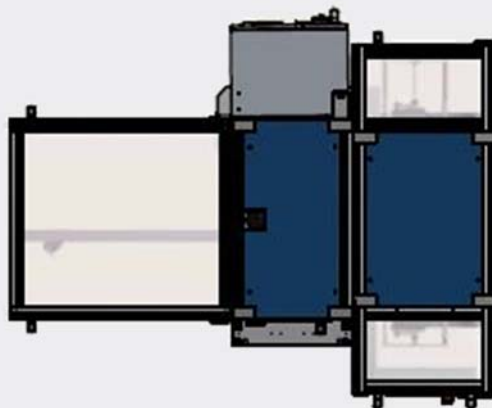
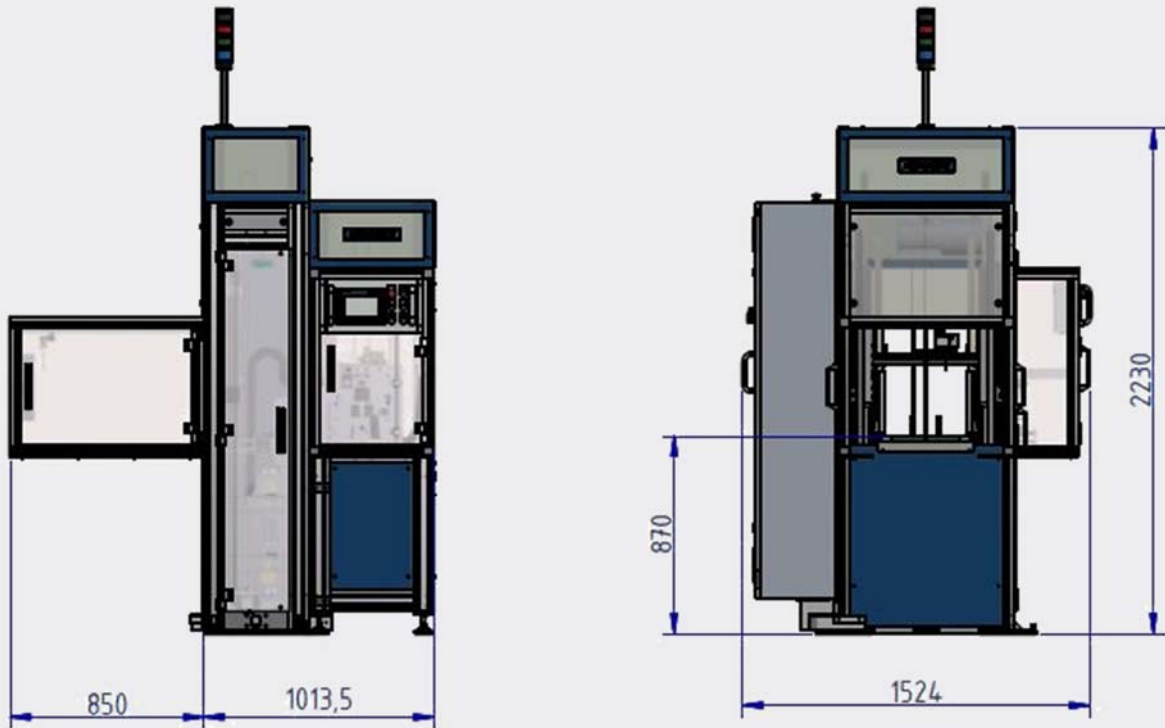

running direction
